

Lancashire and Cheshire Federation of Scottish Societies - AGM Weekend Sat Programme

1 MAXWELL'S RANT R32 · 3/4L

Rutherford: RSCDS XVIII 10 · Crib: Eric's E-cribs · Diagram: Keith Rose's Diagrams

- 1-- Mirror Reels3 on the sidelines (1c cross down) (1x,2,3)
- 9-- 1c cross back into mirror Reels3 on own sides
- 17-- 1c cross RH | cast (2c up) ; ½ Fig8 round 2c
- 25-- 1c dance down between 3c and cast up to 2pl ; 2c+1c+3c turn RH

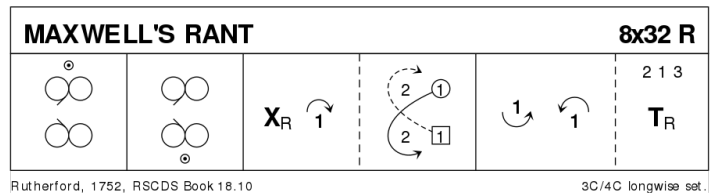

2 STREETS OF MILAN J32 · 3/4L

James & Marilyn Healy · Crib: Eric's E-cribs

- 1-- 1c lead down (2c up) ; 1c lead up | turn RH into promhold facing 2M
- 9-- 1c with 2M+3M Rsh Reel3, finish facing 2W
- 17-- 1c with 2W+3W Lsh Reel3, finish 1c facing up LHJ and 2c facing 3c (2, 1mid, 3)
- 25-- 2c+3c R&L starting up/down **while**{8} 1c lead up, cross, cast off, lead down LHJ, cross, cast up to (2,1,3)

3 ORPINGTON CALEDONIANS R32 · 3/4L

John Brenchley: RSCDS XLIX 2 · Crib: SCDDDB Contributed Cribs & Diagrams · Diagram: Keith Rose's Diagrams

- 1-- 1c set | 1W followed by 1M cast off 1pl (2c up on 5-6) and cross | 1c+3c ½ turn LH on sidelines (1M+3M face out)
- 9-- 1c+3c L-Chain (1M face out)
- 17-- 1M followed by 1W cast up (3c down on 19-20) and cross ; 1c+2c RHA (1M+2W face out)
- 25-- Reels3 on the sides, 1c Lsh to 3c

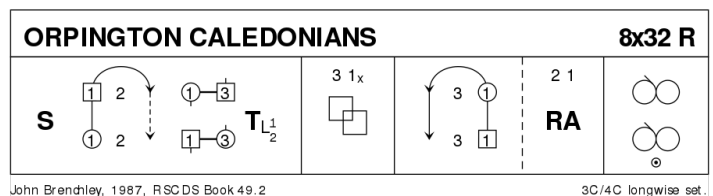

4 CULLA BAY S32 · 4S

Ann Dix: RSCDS XLI 2 · Crib: Eric's E-cribs · Diagram: Keith Rose's Diagrams

- 1- 1c+3c turn RH ½ with person opposite, face that person | twirl R and into opposite place ; 2c+4c repeat this and face in **while**{4} 1c+3c (W leading) chase ¼ clw | curve into centre and swivel R to face out (1c facing 4pl and 3c facing 2pl)
- 9- Parallel Reels4 across
- 17- 2c+1c & 3c+4c circle4 L ; face other couple and set | ½ RHA, flowing into
- 25- 2c+4c LHA in the middle ; dance out passing same sex standing dancer on the side Rsh, and chase R (M leading) to 1pl/3pl (to 2,3,4,1).

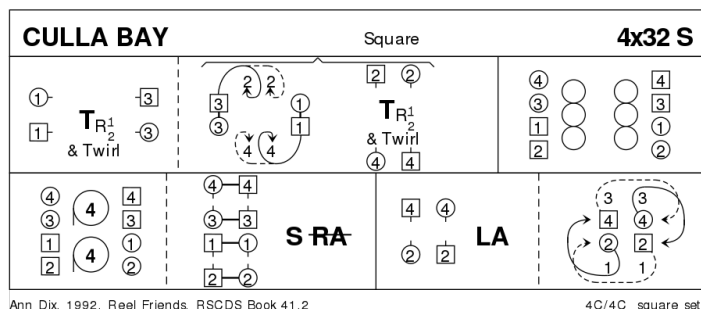

5 NAPIER'S INDEX J40 · 3/4L

Brian Charlton: RSCDS XLV 8 · Crib: Eric's E-cribs · Diagram: Keith Rose's Diagrams

- 1- 1c set | cast off ; turn LH 1¼ into
- 9- 1c+1cnr BiL | 1c+1cnr turn RH {4} | repeat BiL
- 17- 1c+cnr Reels3 on the sides, Lsh to 2cnr, 1c finish LHJ and RHJ with 2cnr
- 25- 1c+2cnr repeat [9-16]
- 33- Reels3 across, 1c Lsh to 3c, at end 1c cross RH as 2c+3c curve into place (2,1,3)

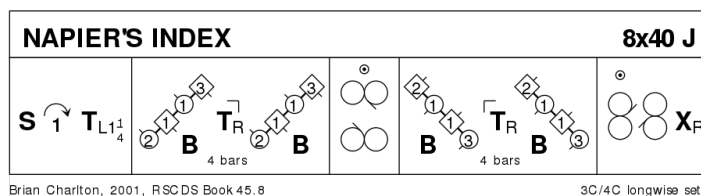

6 RAMADAN-CE R32 · 3/4L

John Drewry: The Turkish Set · Crib: Eric's E-cribs · Diagram: Keith Rose's Diagrams

- 1- 1c+2c+3c Inveran Reels (1,2,3)
- 9- 1c cross RH | cast (2c up) ; Turn RH to face 1cnr
- 17- 1c cast R round 1cnr, pass Rsh in the middle ; cast Rsh round 2cnr to 2plx **while**{8} 1cnr turn RH ½, twirl R and dance out to exchanged places ; 2cnr repeat (3x,1x,2x)
- 25- ½ Reels3 across, 1c Lsh to 3cnr ; ½ Reels3 on the sides, 1c Rsh to 4cnr (2,1,3)

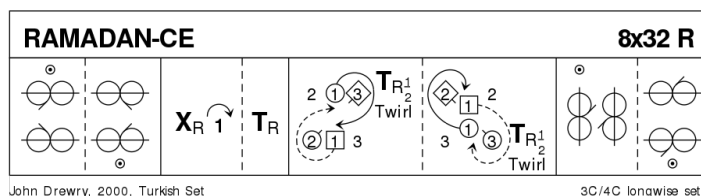

7 THE FLIGHT OF THE FALCON J32 · 3/4L

Barry Priddey: Anniversary Tensome · Crib: Eric's E-cribs · Diagram: Keith Rose's Diagrams

- 1- 1c set and cast off one (2c up), 1¼ turn LH so 1M (with 1W behind) faces 3W
- 9- 1c lead-change diagonal Reel3 with 1cnrs (Rsh to 3W) (1M & 1W switch lead at each end of the reel), end facing 3M
- 17- Repeat with 2cnrs (start Rsh to 3M), finish facing 1cnrs
- 25- Turn 1c nr RH, pass P Rsh, repeat with 2c nr, cross to (2,1,3) (cnrs turn for 4 bars)

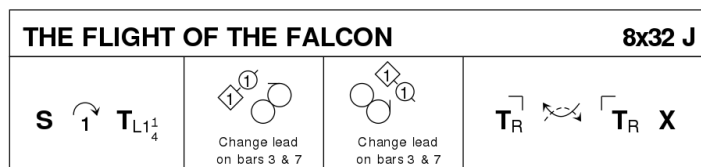

Barry Priddey, Anniversary Tensome

3C/4C longwise set.

8 THE CHEQUERED COURT J32 · 3/4L

Duncan Brown: RSCDS XLII 3 · Crib: Eric's E-cribs · Diagram: Keith Rose's Diagrams

- 1- 1c cross RH | cast off (2c up) ; ½ Fig8 across to the R (1M up, 1W down) to face 1c nr
- 9- 1c+1cnrs pass and turn, at end 1c swivels R to be BtoB facing 4c nr ; 1c+4cnrs pass and turn, 1c swivels R to finish BtoB facing own side for DTr, 1c finish between end couple facing own side
- 17- DTr, 1c finish between end couple facing own side
- 25- Reels3{6} across (Rsh to 4c nr) | 1c cross RH (2,1,3)

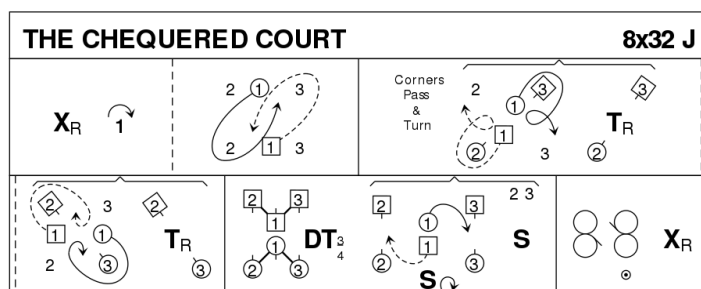

Duncan Brown, 2001, RSCDS Book 42.3

3C/4C longwise set.

9 THE BELLE OF BON ACCORD S32 · 4/4L

John Drewry: Deeside Book Part 2 · Crib: Eric's E-cribs · Diagram: Keith Rose's Diagrams

- 1- 1M cross, cast off round 2W to finish in the middle facing up **while{4}** 1W crosses between 2M and 3M, casts up to the middle facing down **while{4}** 3c do the same round 4c (2c & 4c step up ½ place) ; 1c+2c & 3c+4c RHA
- 9- 1c+3c Reel4 in the centre of the dance
- 17- 1c+3c turn ¾ RH to finish facing up NHJ **while{2}** 2c & 4c dance up ½ place on the sides and in to face down NHJ. All set ; 2c+1c & 4c+3c circle4 L (to sidelines 2,1x,4,3x)
- 25- 1c/3c lead up & cross between 2c/4c and cast off one ; 1c+3c turn BH, opening to face down | 1c dance to 4pl **while{2}** 3c cast up to 2pl. (2,3,4,1)

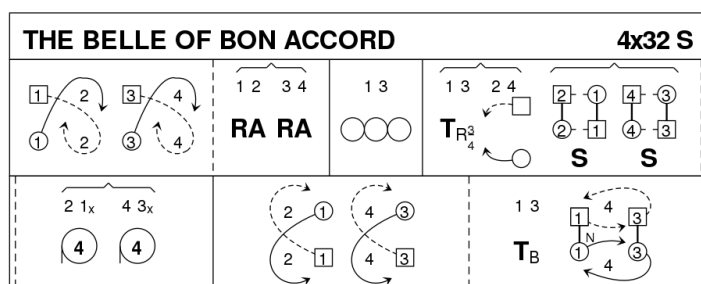

John Drewry, 1981, Deeside Book 2

4C/4C longwise set.

10 THE TWO GRAY CATS R40 · 3/4L

Francis Walduck: *The Other Kangaroo Paw* · Crib: SCDDDB Contributed Cribbs & Diagrams · Diagram: Keith Rose's Diagrams

- 1- 8 1s+2s dance double Fig. of 8, 2s dance up side to start & finish facing out
- 9-16 1s+2s+3s dance Inveran reels with all three couples crossing down from 1st place & up from 3rd place
- 17-24 1s cross RH, cast off, cross down LH between 3s, cast up, pass LSh to finish facing 1st corners (2s step up on bars 19-20)
- 25-32 1s dance Corners Pass & Turn with 1st corners, then with 2nd corners, finishing passing RSh to 2nd place own sides
- 33-40 2s+1s+3s circle 6H round and back

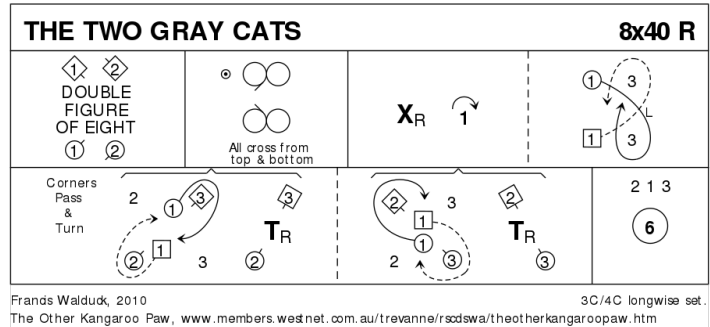

11 QUARRIES' JIG J32 · 3/4L

Kent W Smith: *RSCDS XXXVI 3* · Crib: *Eric's E-cribs* · Diagram: Keith Rose's Diagrams

- 1- 1c set | cast (2c up) ; ½ Fig8 Lsh round 1cnr (2,1x,3)
- 9- 1M+2c and 1W+3c Lsh Reels3 across, at end 1c LH turn to face 1cnrs
- 17- 1c+1cnrs change places RH **while{2}** 2cnrs set | centre dancers change places LH **while{2}** the others chase clw one position ; repeat from new positions
- 25- Repeat from new positions, but to finish 1c turn LH to 2plx ; 2c+1c+3c set | 1c cross RH.

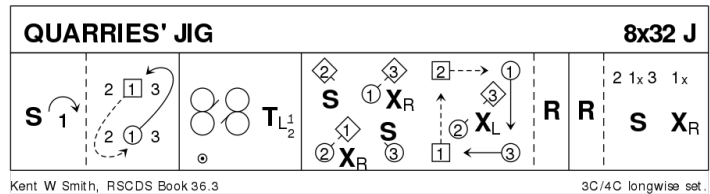

12 NOTTINGHAM LACE R96 · 4S

Jenny Bradley: *Nottingham Lace* · Crib: *Eric's E-cribs* · Diagram: Keith Rose's Diagrams

- 1- Half G-Chain ; all set to P | turn ¾ RH
- 9- All W ½LHA **while{2}** M dance clw one place | all turn new P RH ½ ; repeat (M ½LHA, W ¼ clw)
- 17- Repeat [9-16] to original places
- 25- 1c+3c dance in, change places RH, split and cast behind side C, pass RH to own place, forming a longwise set | All set
- 33- All A&R ; 1c+2W+4M & +3c+2M+4W, circle4 L and open into lines of 4 across with 1c & 3c in the middle
- 41- All A&R ; circle8 half way, finishing in square set opposite original places
- 49-72 Repeat [25-48] with 2c+4c as dancing couples
- 73-96 Repeat [1-24]

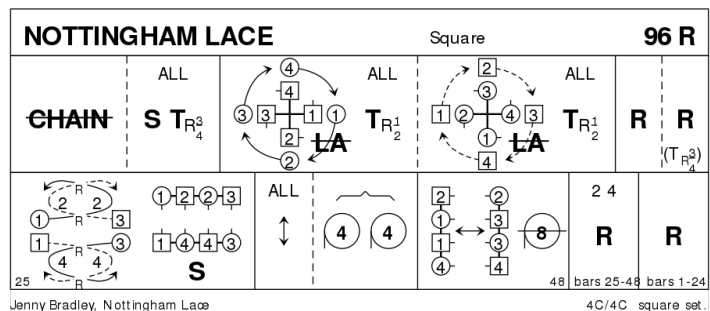

13 RED RUM J32 · 3/4L

Stephen Brown: *The Ribble Valley Book of Scottish Country Dances* · Crib: *MiniCribs* · Diagram: *Keith Rose's Diagrams*

- 1-8 1s set & cross RH, 1s set to 2s on sides & 1/2 turn LH
- 9-16 1s+2s dance Ladies' Chain & end with 1s facing 1st corners
- 17-24 1s set to 1st corners & turn 2H, 1s set to 2nd corners & turn 2H
- 25-32 1s dance reels of 3 on opposite sides giving LSh to 1st corner cross to 2nd place own sides

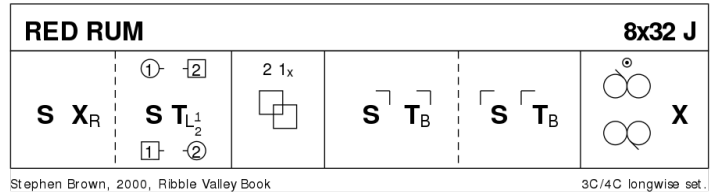

14 FAR NORTH QUEENSLAND S32 · 5/5L

John Brendhley: *The Other Kangaroo Paw* · Crib: *MiniCribs* · Diagram: *Keith Rose's Diagrams*

- 1-4 1s+ 5s cross RH & cast down/up 1 place (2s+4s step up/down)
- 5-8 1M+2s also 1L+3s+5M also 5L+4s dance circles round to Left. 1s+5s end in middle facing partners (Men facing down, Ladies facing up)
- 9-16 1s+5s set, dance 1/2 reel of 4, set advancing to partners, pass LSh to face 2nd corner positions
- 17-24 1s+5s dance 1/2 diag. reel of 4 with 2nd corners, turn LH to face 1st corner positions, dance 1/2 diag. reel of 4 with 1st corners, turn LH to face 4th corner positions (partner's 2nd corner position)
- 25-32 1s+5s dance 1/2 diag. reel of 4 with 4th corners, turn LH to face out on own sides, cast 1 place (3s+2s step up 31-32) 4 3 5 2 1

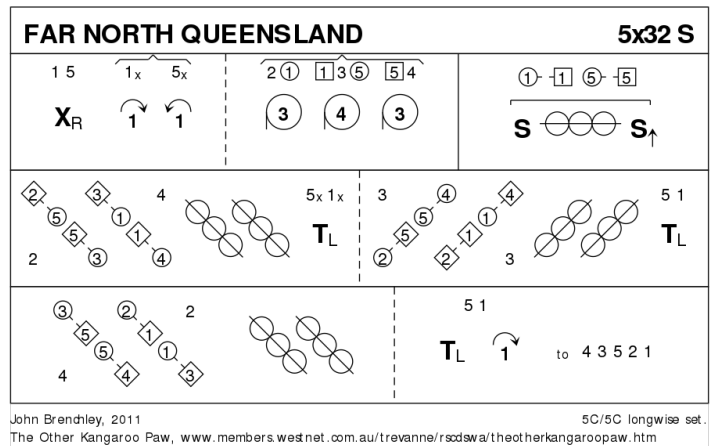

15 CURRIE MOUNTAIN R32 · 3/4L

Mary Pugh: *New Brunswick Collection* · Crib: *Eric's E-cribs* · Diagram: *Keith Rose's Diagrams*

- 1- 1c cross RH, cast off one (2c up) ; 1/2 Fig8 up round 2c (2,1,3)
- 9- 1c (start inwards) turn 3C EH ; 1c turn 2C EH (2,1,3)
- 17- 1c+3c RHA ; 1c+2c LHA
- 25- 2c+1c+3c Reels3 on the sides, 1c giving Rsh to 3c (2,1,3)

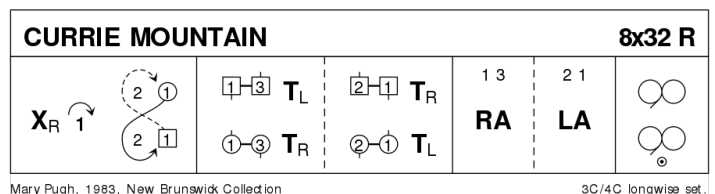

After the second turn the dancing couple continues the reel with bottom couple to change places.

16 BEST SET IN THE HALL J32 · 3/4L

Helen Greenwood: RSCDS XLVI 7 · Crib: Eric's E-cribs · Diagram: Keith Rose's Diagrams

- 1- 1c set | 1W (1M follows) casts off 2, crosses, W dances up behind M line, and M dances up the middle, 1c face 1cnr (2c up)
- 9- 1c set to 1cnr | 1c cast Rsh round each other to 3cnr position **while{2}** 1cnrs dance into centre, and swivel R to face own cnr ; repeat, 1cnrs finishing in exchanged places, and 1c facing 2cnr
- 17- Repeat with 2cnrs (3x,1x,2x)
- 25- All chase clw ½ round ; all turn RH. (2,1,3)

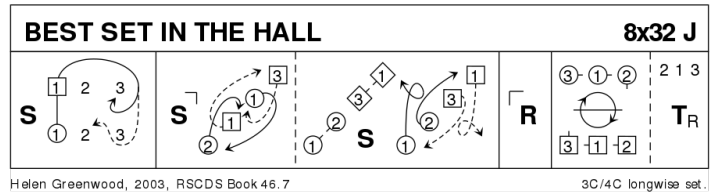

To: Auckland Region President, Campbell MacKay, nov. 2003

17 THE IRISH ROVER R32 · 3/4L

James B Cosh: Twenty Two SCD · Crib: Eric's E-cribs · Diagram: Keith Rose's Diagrams

- 1- 1c lead through 3c (2c up) and cast up ; 1M+3c and 1W+2c RHA, finish facing 1cnrs.
- 9- 1c+1cnrs ½Reel4, pass Lsh ; ½Reel4 with 2cnrs, fast ¾ LH turn in the centre
- 17- 1W+3c (at top) & 1M+2c Reels3 across (Lsh to 1cnr pos), (to 3x,1,2x)
- 25- diagonal R&L (1M down,1W up) (2,1,3)

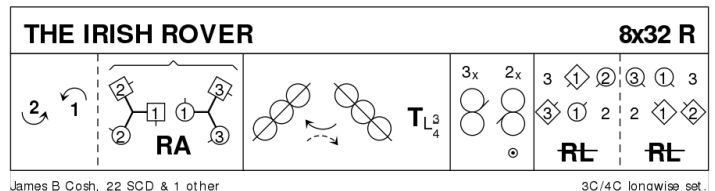

18 THE GLENGARRY HOMESTEAD S32 · 4/4L

John Brendhley: The Kangaroo Paw · Crib: Eric's E-cribs · Diagram: Keith Rose's Diagrams

- 1-- 1c ½ Fig8 with 2c **while{}** 3c ½ Fig8 with 4c ; 1c&3c dance down one and turn inwards to face up NHJ **while{}** 2c&4c dance up one on sidelines, turn inwards to face down NHJ | All set
- 9-- 2c+1c & 4c+3c Circle4 to L ; ½ Reels4 on sidelines, on [15-16] 1c+4c turn LH ¾ to finish in line across, W in centre, ready for
- 17-- 1c+4c The Targe: W turn RH ¾ as M chase cclw ¼ onto midline | W+M turn LH ; repeat [17-20] to finish on sidelines (3x,1,4x,2)
- 25-- ½ Reels4 on sidelines ; All set | 4c&3c cross RH (2,4,1,3)

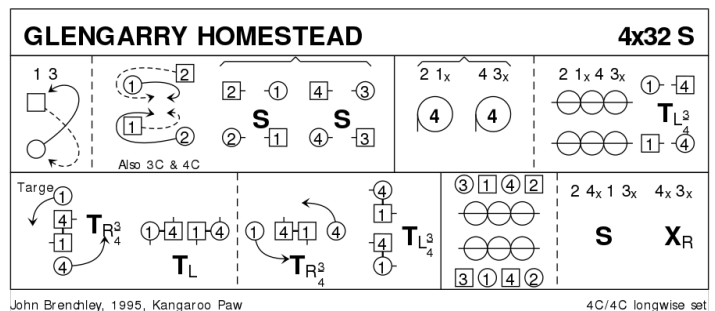

19 THE CRANBERRY TART J32 · 3/4L

Terry Glasspool: Dances from the Seven Year Itch · Crib: Eric's E-cribs · Diagram: Keith Rose's Diagrams

- 1-16 Fugue: 1M set | cast (2M up) ; set | petronella to between 3c ; set with 3c | advance with 3c ; retire with 3c | advance alone **while{16}** 1W waits {2} and then repeats 1M's [1-14], dancing with 2W and 2c, on [16] 1W pivots R to give Rsh to 2W
- 17- 1W with 1M following Reel3 across with 2c, finish (2,1,3)
- 25- Parallel Reels3 on own sides, 1c Rsh to 3c (2,1,3)

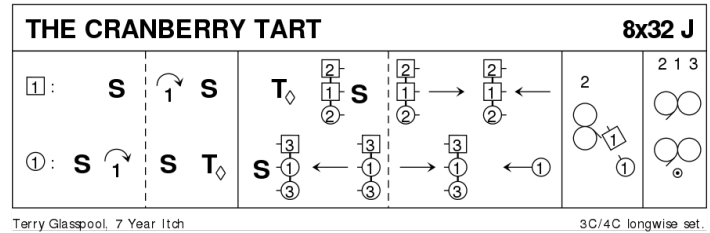

20 MISS JOHNSTONE OF ARDROSSAN R32 · 5/5L

Roy Goldring: 14 Social Dances for 2000 · Crib: Eric's E-cribs · Diagram: Keith Rose's Diagrams

- 1- 1c set | cast off (2c up) ; 1c followed by 3c dance up and cast round 2c to (2,3,1,4,5)
- 9- 1c+4c+5c mirror Reels3, 1c cross down to enter, 4c start out and up (2,3,1x,4,5)
- 17- 2c+3c+1c mirror Reels3, 1c cross up to enter, 3c start out and down
- 25- 1c set | cast off to 4pl (4c up) ; 1c followed by 5c dance up and cast round 4c to (2,3,4,5,1)

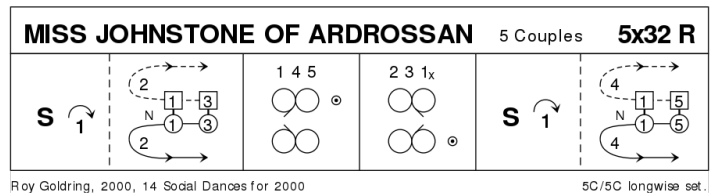

21 SETON'S CEILIDH BAND J64 · 4/4L

A Bruce Fordyce: The Bruce Fordyce Memorial Collection · Crib: Eric's E-cribs · Diagram: Keith Rose's Diagrams

- 1- 1c cross RH, cast (2c up) ; dance between 3c (3c up) , behind 4c (4c up) to (2,3,4,1x)
- 9- 3c+4c+1c Reel3 on side (1c in, 4c out and down to begin)
- 17- 1c repeat bars 1-8 from 4th position, dancing up the set (1,2,3,4)
- 25- 1c+2c+3c Reels3 on side (1c in, 2c up and out to begin)
- 33- 1c cross RH | cast (2c up) and give RH to P, LH to 1cncr ; BiL, 1c turn RH to 2cncr
- 41- 1c+2cncr BiL, 1c cast off behind 3c, lead up RH crossing over to 1pl own side facing down (2c down)
- 49- 1c+2c ½ R&L, giving RH on the side to begin ; repeat with 3c
- 57- Repeat with 4c ; all C turn RH 1½.

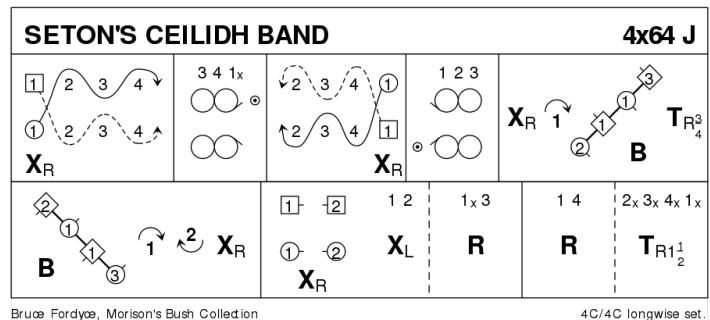

22 DUKE OF PERTH R32 · 3/4L

RSCDS 18 · Crib: Eric's E-cribs · Diagram: Keith Rose's Diagrams

- 1- 1c turn RH, cast off (2c up) ; turn LH to face 1cnrs
- 9- Turn CPCP, to face 1cnrs
- 17- 1c set to and turn 1cnrs BH ; set to and turn 2cnrs BH
- 25- Reels3{6} on the sides (Lsh to 1c) | 1c cross RH to 2pl.

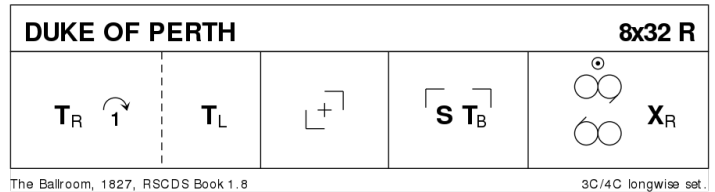

23 THE RAVEN'S DANCE J32 · 3/4L

Derek Haynes: Carnforth Collection of SC Dances 5 · Crib: Eric's E-cribs · Diagram: Keith Rose's Diagrams

- 1- 1c+2c DbIFig8 (1c cross down, 2c dance up, no cast), at the end 2c face out
- 9- Crossover Reels3 on the sides (1c cross down, 2c out and up), finish 1c side by side at top facing down, W on the R, 2c facing out
- 17- 1c (together) +2c Lead-change Reel3 across, Rsh to 2M. 2c finish in 1pl with 1c in between facing down
- 25- 1c dance down, cast up round 3c, lead up, cross between 2c and cast off (2,1,3)

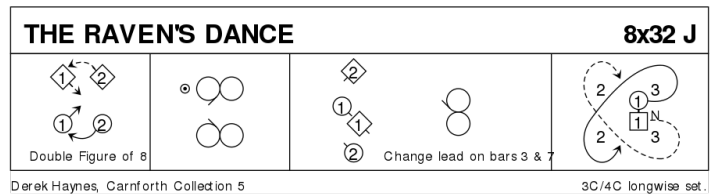

24 INDIAN RIVER STRATHSPEY S32 · 3T

George Senyk: Scottish Country Dances in Diagrams, Supplement to the 8th Edition · Crib: Eric's E-cribs · Diagram: Keith Rose's Diagrams

- 1- All in promhold Reel3 across (1c & 3c Rsh to begin).
- 9- With 1W leading, 1c+3c RHA ; 1c+2c LHA
- 17- 2c+3c L-Chain **while** 1c set | dance down the middle & cast up round the outside to orig. place.
- 25- 1c+3c ½R&L ; 1c+2c ½R&L. (to 3,1,2)

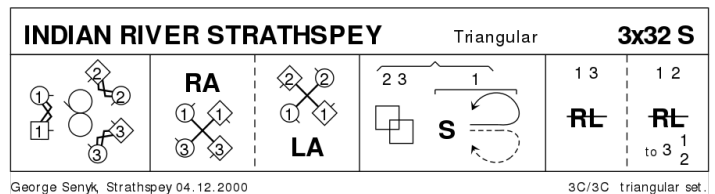

25 THE FALLS OF ROGIE R32 · 3/4L

Jean Attwood: Alexander Dances Book 1 · Crib: Eric's E-cribs · Diagram: Keith Rose's Diagrams

- 1- 1c cross RH | cast (2c up) ; cross RH | cast R (M up, W down)
- 9- ½ Reels3 across (Lsh to 2cnr) ; set in lines across | all cross up/down RH
- 17- Corners chase once clw **while{8}** 1c chase half way clw and turn RH 1¼ to face 1cnr positions
- 25- ½ diag. Reel4 with 1cnrs, 1c pass Rsh ; ½ diag. Reel4 with 2cnrs, 1c passing Rsh to 2pl.

